



# FOLDABLE PLATFORM PALLET TRUCK T20 AP | T25 AP

**CAPACITY 2000 - 2500 KG | SERIES 1153**

## Safety

This pallet truck with foldable side guards is perfectly designed to protect the operator during the work shift. Automatic speed reduction when cornering, automatic braking on releasing the traction control and excellent visibility through the wide mast, all provide assured safety. Electromagnetic braking is actuated by the dead man platform or by the emergency stop button and is proportional to the load carried.

## Performance

Highly efficient productivity is the Linde pallet truck's true strength. The compact and powerful 2.3kW AC drive unit which offers speeds up to 10km/h and the innovative castor wheels enable precise maneuvering and ensure the optimum mix of stability and traction in all situations. This all adds up to efficient and safe transfer of loads up to 2.5t.

## Comfort

The fully suspended operator compartment keeps the driver concentrated and maintains high efficiency levels throughout the work shift. All controls on the ergonomic tiller head can be easily operated

by either hand. Tasks are made easier thanks to the generous storage compartments for work equipment, such as shrink wrap.

## Reliability

The highly durable, robot welded construction of the pallet truck ensures consistent reliability and a long life in reference to applications. Each heavy cast fork tip can support a load of 2000 kg without deformation. Smooth entry into bottom boarded pallets is assisted by the ski contours of the underside of the fork tips. The arrow shaped fork tips also facilitate easy entry into every type of pallet and due to shrink wrapping, it also ensures fast, efficient, and safe load handling.

## Service

A maintenance-free AC motor reduces service costs. Operating parameters can be individually adjusted to the operator's needs via the CAN-bus system. The service engineer has fast, easy access not only to truck data, via the CAN-bus system, but also to all main internal components.

# TECHNICAL DATA

## ACCORDING TO VDI 2198

			LINDE		
			T20 AP	T25 AP	
Characteristics	1.1	Manufacturer		LINDE	LINDE
	1.2	Model design			
	1.3	Power unit		Battery	Battery
	1.4	Operation		Standing	Standing
	1.5	Load capacity / Load	Q (t)	2.0	2.5
	1.6	Load centre distance	c (mm)	600	600
	1.8	Axle centre to fork face	x (mm)	965	965
	1.9	Wheelbase	y (mm)	1478	1478
Weight	2.1	Service weight	(kg)	875	875
	2.2	Axle load with load, front / rear	(kg)	983 / 1920	1090 / 2356
	2.3	Axle load without load, front / rear	(kg)	710 / 165	710 / 165
Wheels and types	3.1	Tyres rubber, SE, pneumatic, polyurethane		R + P / P	R + P / P
	3.2	Tyre size, front	(mm)	230 x 90	230 x 90
	3.3	Tyre size, rear	(mm)	85 x 85 (bogies 85 x 60)	85 x 85 (bogies 85 x 60)
	3.4	Auxiliary wheels (dimensions)	(mm)	2 x 125 x 60	2 x 125 x 60
	3.5	Wheels, number front / rear (x = driven)	(mm)	1x+2/2(1x+2/4)	1x+2/2(1x+2/4)
	3.6	Track width, front	b <sub>10</sub> (mm)	502	502
	3.7	Track width, rear	b <sub>11</sub> (mm)	380	380
Dimensions	4.4	Lift	h <sub>3</sub> (mm)	125	125
	4.9	Height of tiller arm in operating position, min / max	h <sub>14</sub> (mm)	1160 / 1300	1160 / 1300
	4.15	Height, lowered	h <sub>13</sub> (mm)	86	86
	4.19	Overall length	l <sub>1</sub> (mm)	2350	2350
	4.20	Length to fork face	l <sub>2</sub> (mm)	1195	1195
	4.21	Overall width	b <sub>1</sub> / b <sub>2</sub> (mm)	720	720
	4.22	Fork dimensions DIN ISO 2331	s / e / l (mm)	55 x 165 x 1150	55 x 165 x 1150
	4.24	Width of fork carriage	b <sub>3</sub> (mm)	710	710
	4.25	Fork spread	b <sub>5</sub> (mm)	520 / 540 / 560 / 680	520 / 540 / 560 / 680
	4.32	Ground clearance, centre of wheelbase	m <sub>2</sub> (mm)	30	30
	4.34.1	Aisle width for pallets 1000 x 1200 crossways	A <sub>31</sub> (mm)	2830	2830
	4.34.2	Aisle width with pallet 800 x 1200 along forks	A <sub>31</sub> (mm)	2965	2965
	4.35	Turning radius	W <sub>a</sub> (mm)	2095 / 2165	2095 / 2165
	Performance	5.1	Travel speed, with / without load	(km/h)	10.0 / 10.0
5.2		Lifting speed, with / without load	(m/s)	0.036 / 0.046	0.028 / 0.036
5.3		Initial lowering speed	(m/s)	0.090 / 0.089	0.066 / 0.072
5.8		Maximum climbing ability, with / without load	(%)	12.0 / 20.0	10.0 / 20.0
5.9		Acceleration time, with / without load	(s)	6.02 / 4.76	6.24 / 4.76
5.10		Service brake		Electromagnetic	Electromagnetic
Drive	6.1	Drive motor rating S2 60 min	(kW)	2.3	2.3
	6.2	Lift motor rating at S3 15%	(kW)	1.2	1.5
	6.3	Battery according to DIN 43531/35/36 A,B,C,no		3PZs SL	3PZs SL
	6.4	Battery voltage / rated capacity (5h)	(V) / (Ah)	24 / 375	24 / 375
	6.5	Battery weight (± 5%)	(kg)	290	290
	6.6	Power consumption according to VDI cycle	(kWh/h)	0.454	0.454
8.1	Type of drive unit		LAC	LAC	
10.7	Sound pressure level LpAZ (at the driver's seat)	(dB(A))	61	61	

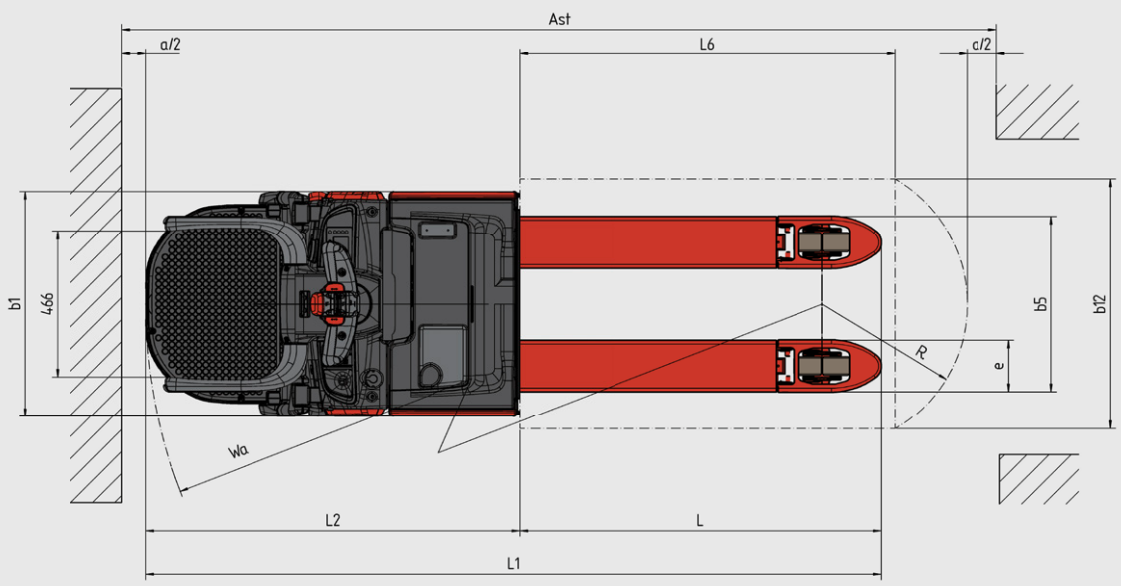
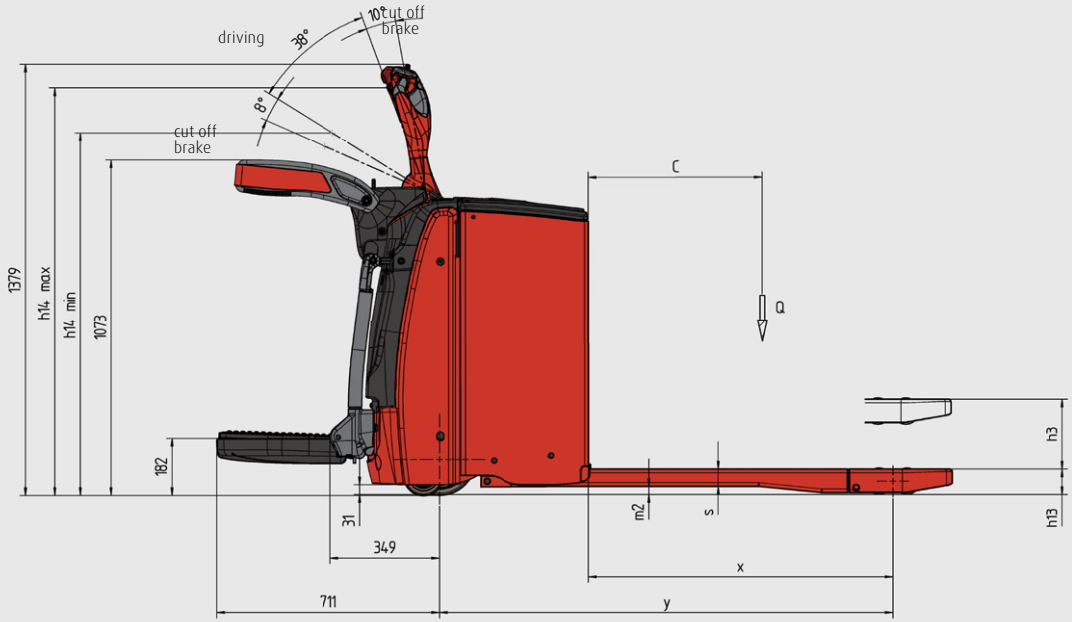

# STANDARD EQUIPMENT / OPTIONAL EQUIPMENT

## STANDARD EQUIPMENT

720 mm chassis width smaller than a pallet
Fully suspended operator compartment
Foldable stand-on platform with side guards
Power assisted steering with variable steering resistance
Polyurethane drive wheel
Polyurethane single load wheels
Multifunction coloured display of the hour meter, maintenance indication, battery discharge indicator and internal fault code indication
Creep speed
2.3 kW AC maintenance-free drive motor
CAN bus technology
Automatic speed reduction when cornering
Automatic braking
Electromagnetic emergency brake acting proportionally to the load weight
Vertical 3PzS battery compartment
Protection: -10°C

## OPTIONAL EQUIPMENT

Drive wheels: cushion, cushion with tread, non-marking or wet grip
Load wheels: tandem polyurethane or single/tandem polyurethane greasable load wheels
Hydraulic castor wheels
Alternative fork dimensions
Load backrest 1800 mm / 1200 mm
Working lamp LED front
Blue spot
Accessory support
Support data terminal incl. power supply cable 24V
Support clipboard DIN A4
Support for scanner
Built-in charger
Vertical 2PzS battery compartment
Vertical 4PzS battery compartment
Lateral 3PzS battery compartment
Lateral 4PzS battery compartment
Battery stand – fixed and mobile
Working lamp LED front
Other options available on request

### Linde Connected Solutions:

ac: access control (PIN or RFID Dual),  
an: usage analysis and dt: crash detection

Data transfer online

Data transfer WIFI

Bluetooth USB Stick

### Li-ION technology:

3PzS compartment with 4.5 kWh - 9 kWh (205 Ah - 410 Ah)

### Li-ION charger:

24V-Charger v255: 4.5 kWh (full charging time 1h 30 min) -  
9.0 kWh (2h 40 min)



# FEATURES

## Platform

- Fully suspended operator compartment
- Platform and handle bar are decoupled from the chassis
- Reduced vibrations for the legs and for the upper body
- Soft, slip-proof rubber padding
- Entire platform surface acts as an operator detection switch
- Foldable side guards



## Power steering for comfort and safety

- Steering effort adjusts automatically to speed and turning radius
- Speed is automatically reduced, in relation to the steering angle
- The result is effortless maneuvering and safe, highly efficient load handling

## Handling

- 720 mm chassis width narrower than a pallet
- Compact and robust chassis for easy handling in narrow spaces
- A Creep speed button ensures high maneuverability in confined areas when operating with the tiller in an upright position

## Braking

- Highly efficient mechanical brake when the tiller is fully raised or lowered
- Automatic electric braking on releasing the butterfly control or reversing direction
- Truck slows down prior to stopping - remaining under complete control at all times
- No roll-back when starting on a slope

## AC Motor

- Compact, efficient and maintenance-free 2.3kW AC motor
- Innovative castor wheel design offers maximum traction and stability for demanding applications, such as, loading/unloading

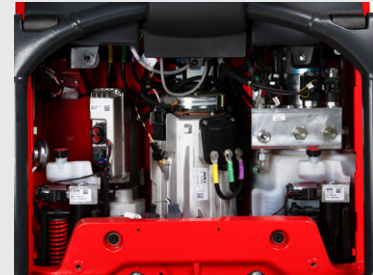

## Workstation

- All controls are ergonomically integrated in the tiller head
- Multifunctional instrument display with an easy, ergonomic menu
- Truck access control by PIN code or ignition key
- Storage compartment for work gloves, writing utensils, etc.
- Emergency isolator

## Comprehensive energy solutions

- 24V batteries: capacities from 345Ah (3PzS) to 500Ah (4PzS)
- Li-ION batteries with 4.5kWh (205Ah) and 9.0kWh (410Ah)
- Optional built-in charger available
- Optional lateral change, including rollers inside the battery compartment and a lever to aid battery change

## CAN-bus connectivity

- On-board diagnostics and CAN-bus interface
- Provides service technician with rapid access to all truck data for performance parameter settings, trouble shooting, and preventative maintenance

Subject to modification in the interest of progress. Illustrations and technical details could include options and not binding for actual constructions. All dimensions subject to usual tolerances.

Presented by:

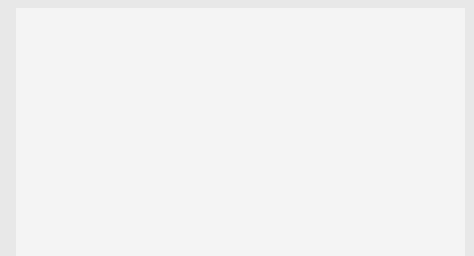

**Linde Material Handling GmbH**  
Postbox 10 0136 | 63701 Aschaffenburg | Germany  
Phone + 49 6021 99 0 | Fax + 49 6021 99 15 70  
www.linde-mh.com | info@linde-mh.com

Printed in Germany 790.e.1.0620.IndB.Ki